

1105 Universal Transmitter

Description

The Model 1105 is a two input transmitter typically used for door/window applications and provides a cover tamper, magnetic reed switch and on-board terminal block to allow for external contact wiring. Both sets of contacts, internal and external, can be programmed to operate at the same time allowing for two independent zones from one transmitter.

Compatibility

All DMP 1100 Series Wireless Receivers and Panels

What is Included

The 1105 Universal Transmitter includes the following items:

- One 1105 Transmitter PCB mounted in a two-part housing (base and cover)
- Magnet with standard or commercial housing and base
- One 3V lithium CR123A Battery
- Hardware pack
- Serial number label
- Double-sided tape for transmitter and standard magnet housing

Transmitter Serial Number

For your convenience, an additional pre-printed serial number label is included. Prior to installing the device, record the serial number or place the pre-printed serial number label on the panel programming sheet. This number is required during programming. As needed, use the zone name and number label to identify a specific transmitter.

Programming the Transmitter in the Panel

Refer to the programming guide as needed. Program the device as a zone in **Zone Information** during panel programming. At the Serial Number: prompt, enter the eight-digit serial number. Continue to program the zone as directed in the panel programming guide.

Note: When a receiver is installed, powered up, or the panel is reset, the supervision time for transmitters is reset. If the receiver has been powered down for more than one hour, wireless transmitters may take up to an additional hour to send a supervision message unless tripped, tampered, or powered up. This operation extends battery life for transmitters. A missing message may display on the keypad until the transmitter sends a supervision message.

Selecting the Proper Location (LED Survey Operation)

The 1105 Transmitter provides a built-in survey capability to allow one person to confirm transmitter communication with the receiver while the cover is removed. The 1105 Transmitter PCB Red Survey LED turns on whenever data is sent to the receiver then immediately turns off when the receiver acknowledgement is received. Pressing the tamper switch is a convenient way to send data to the receiver to confirm operation. When the tamper switch is pressed or released, the LED blinks once to indicate proper operation. When the transmitter does not receive an acknowledgement from the receiver the LED remains on for about 8 seconds to let you know communication is not established. Communication is also faulty when the LED flashes multiple times in quick succession. Relocate the transmitter or receiver until the LED immediately turns off indicating the transmitter and receiver are communicating properly. Proper communication between the transmitter and receiver is verified when for each press or release of the tamper switch, the LED blinks immediately on and immediately off. Repeat this test to confirm five separate consecutive LED blinks. Any indication otherwise means proper communication has not been established.

Mounting the Transmitter and Magnet Assemblies

For internal contact operation, the transmitter and magnet assembly should have no more than 1/2" space between the assembled housings after installation. When mounting on metal (ferrous) surfaces, this distance is slightly less. For door installations, it is recommended the transmitter be mounted on the door frame and the magnet assembly be mounted on the door.

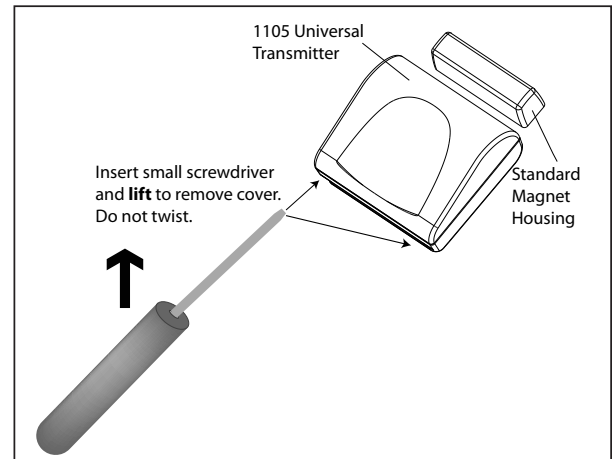

Figure 1: Transmitter and Magnet

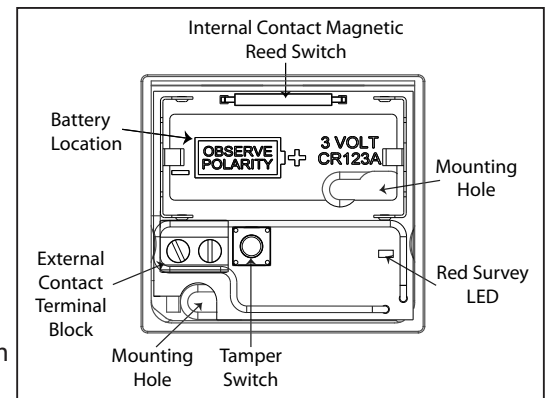

Figure 2: 1105 PCB Layout

Magnet Assembly

Only one magnet assembly is required for internal reed switch operation. Depending on the installation requirements, either the Standard Magnet Assembly (Figure 3) or the Commercial Magnet Assembly (Figure 4) can be used. Snap the supplied magnet into the desired housing prior to mounting.

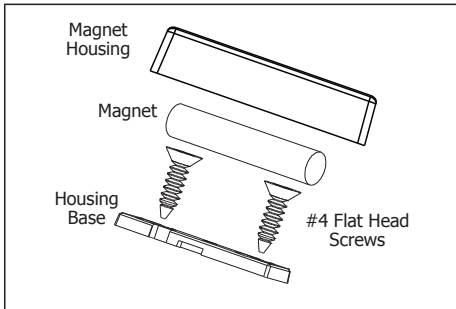

Figure 3: Standard Magnet Assembly

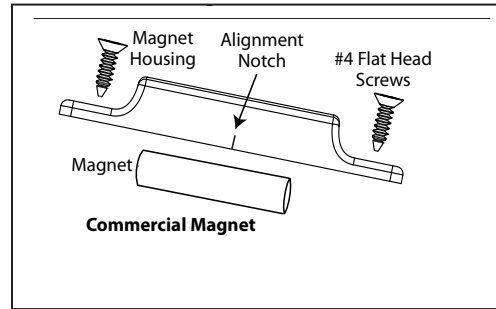

Figure 4: Commercial Magnet Assembly

Installing the Transmitter

The following instructions cover installing the transmitter and magnet assembly.

1. Remove the cover and battery if installed. See Figure 1.
2. Hold the transmitter base in place with the reed switch nearest to the area where the magnet is to be mounted.
Note: There is no need to remove the PCB from the housing during installation.
3. Place two supplied #4 flat head screws into the mounting hole locations as shown in Figure 5 and 6 to secure the housing to the surface.
4. When using the standard magnet, place the magnet base on the surface nearest to the internal reed switch location and use the provided #4 flat head screws to secure the magnet base in place. Snap the magnet into the standard housing, then snap the housing onto the base.
5. When using the commercial magnet, snap the magnet into the commercial housing, then using the supplied #4 flat head screws, mount the magnet in the desired location.

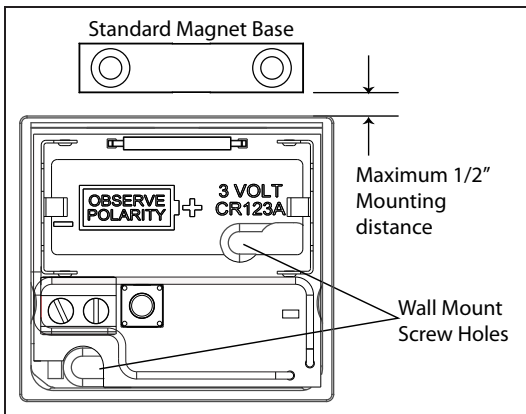

Figure 5: Transmitter and Standard Magnet

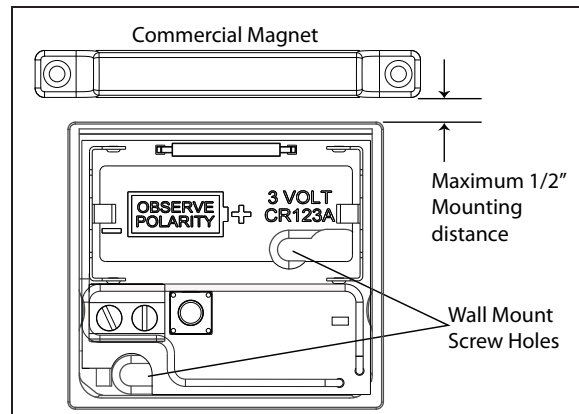

Figure 6: Optional Commercial Magnet

1105 External Contact Mounting

When connecting an external contact to the terminal block, DMP recommends using 18 or 22-gauge unshielded wire. **Do not** use twisted pair or shielded wire. Connect the external contact as normally open (N/O) or normally closed (N/C) without any end-of-line resistor. Refer to the Normally Open NO YES option under Zone Information in the appropriate panel programming guide.

Note: When using both the internal reed switch and external terminal block, you must use consecutive zone numbers. Refer to the following examples:

- **XR500 system** – zones 562 and 563 or zones 893 and 894
- **XR550 system** – zones 523 and 524 or zones 793 and 794
- **XT30/XT50 Series** – zones 31 and 32 or zones 34 and 41

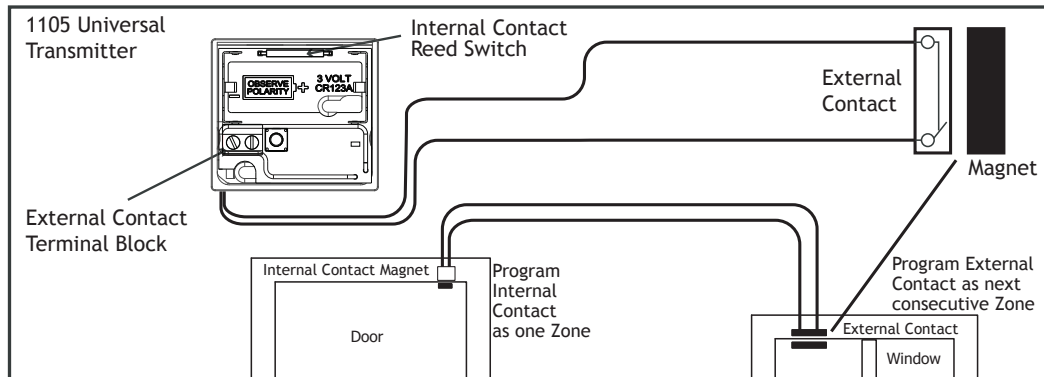

Figure 7: External Contact Wiring

Installing or Replacing the Battery

Observe polarity when installing the battery. Reversing the battery will damage the transmitter. Use only 3.0V lithium batteries, DMP Model CR123, or the equivalent battery from a local retail outlet. For UL installations, only use #123 batteries manufactured by Energizer for the 1105.

Note: When setting up a wireless system, it is recommended to program zones and connect the receiver before installing batteries in the transmitters.

1. If installed, remove the transmitter housing cover as shown in Figure 1.
2. If replacing the battery, remove the old battery and dispose of it properly.
3. Place the 3.0V lithium battery in the holder as shown in Figure 2 and press into place.
4. Align the back of the transmitter cover next to the battery and snap the cover into place.



Caution: Risk of fire, explosion, and burns. Do not recharge, disassemble, heat above 212 °F (100 °C), or incinerate. Properly dispose of used batteries.

Battery Life Expectancy

Typical battery life expectancy for DMP Model 1105 wireless transmitters is 5 years. DMP wireless equipment uses two-way communication to extend battery life.

The following situations can reduce battery life expectancy:

- If a receiver is unplugged or not installed.
Note: Transmitters continue to send supervision messages until a receiver returns an acknowledgement. After an hour the transmitter only attempts a supervision message every 60 minutes.
- Frequent transmissions, such as a door contact where messages are sent every time the door opens or closes.
- When installed in extreme hot or cold environments.

The following situation can extend battery life expectancy:

- Extend transmitter supervision time in panel programming.
- Infrequent transmission trips, such as a window that rarely sends messages.

FCC Information

This device complies with Part 15 of the FCC Rules. Operation is subject to the following two conditions:

- (1) This device may not cause harmful interference, and
- (2) this device must accept any interference received, including interference that may cause undesired operation.

The antenna used for this transmitter must be installed to provide a separation distance of at least 20 cm from all persons. It must not be co-located or operated in conjunction with any other antenna or transmitter.

Changes or modifications made by the user and not expressly approved by the party responsible for compliance could void the user's authority to operate the equipment.

NOTE: This equipment has been tested and found to comply with the limits for a Class B digital device, pursuant to part 15 of the FCC Rules. These limits are designed to provide reasonable protection against harmful interference in a residential installation. This equipment generates, uses and can radiate radio frequency energy and, if not installed and used in accordance with the instructions, may cause harmful interference to radio communications. However, there is no guarantee that interference will not occur in a particular installation. If this equipment does cause harmful interference to radio or television reception, which can be determined by turning the equipment off and on, the user is encouraged to try to correct the interference by one or more of the following measures:

- Reorient or relocate the receiving antenna.
- Increase the separation between the equipment and receiver.
- Connect the equipment into an outlet on a circuit different from that to which the receiver is connected.
- Consult the dealer or an experienced radio/TV technician for help.

Compliance Listing Specifications

Universal Specification

For any UL Listed installation, do not use double-sided tape.

Household Burglar-Alarm System Units ANSI/UL 1023

Install only on non-conductive surfaces.

Specifications		Certifications	
Battery		California State Fire Marshal (CSFM)	
Life Expectancy	5 years (normal operation)	FCC Part: CCKPC0124	
Type	3.0V lithium CR123A	Industry Canada: 5251A-PC0124	
See Battery Life Expectancy for full details.		ANSI/UL 1023 Household Burglar Alarm System Units	
Frequency Range:	903-927 MHz	ANSI/UL 634 Connections and Switches for use with Burglar Alarm Systems Accessory	
Dimensions			
Transmitter Case	1.75" L x 1.6" W x 0.79" H		
Standard Magnet Housing	1.35" L x 0.375" W x 0.425" H		
Commercial Magnet Housing	2.25" L x 0.375" W x 0.34" H		
Color	White		
Housing Material	Flame retardant ABS		
Patents			
U. S. Patent No. 7,239,236			
		INTRUSION • FIRE • ACCESS • NETWORKS	
800-641-4282		2500 North Partnership Boulevard	
www.dmp.com		Springfield, Missouri 65803-8877	
Designed, Engineered and Assembled in U.S.A.			